

VCO SH2 - G. De Luca

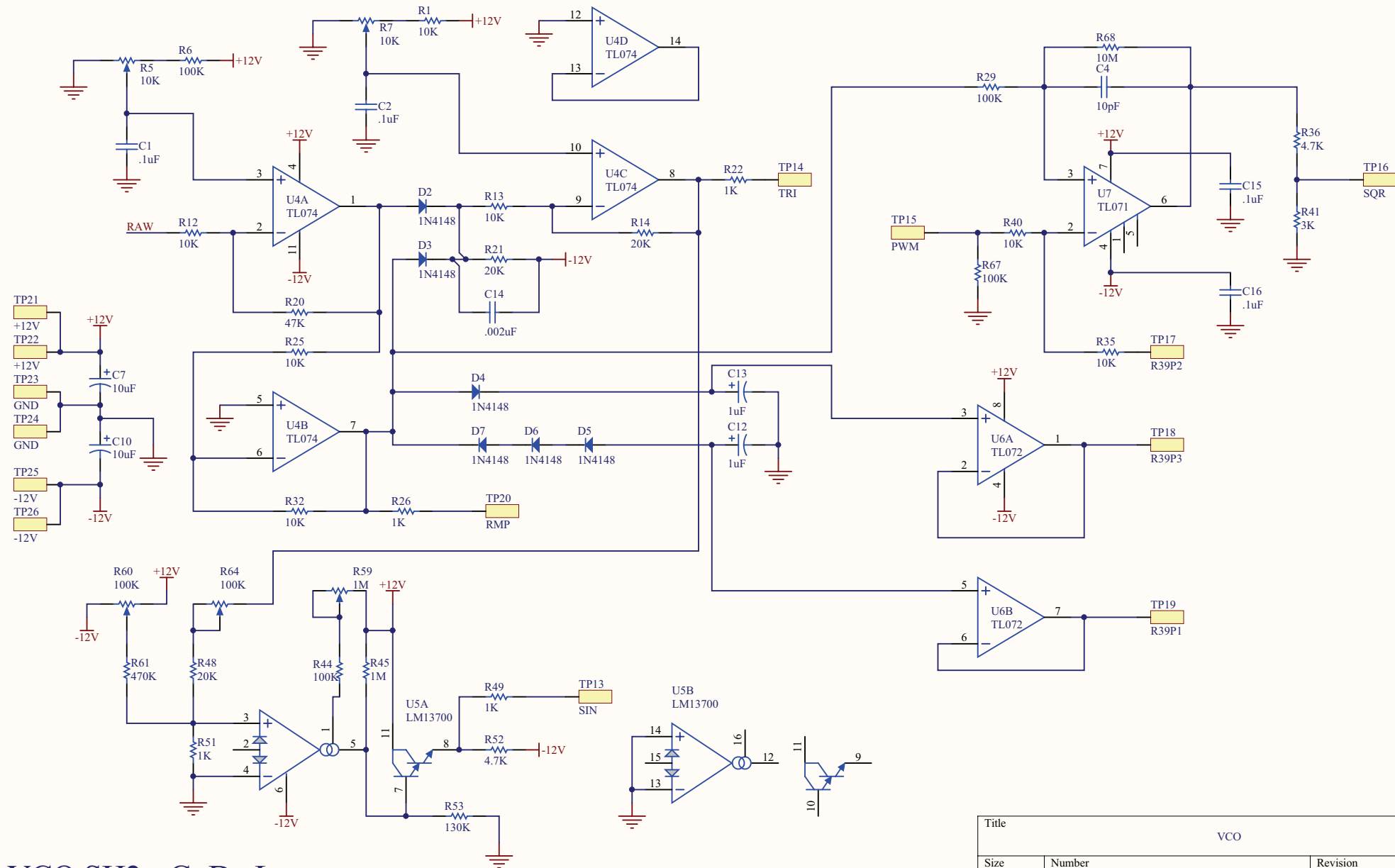

Title		
VCO		
Size	Number	Revision
A4	1	1
Date:	25/06/2011	Sheet of 2/2
File:	C:\0_Mieiv\...VCO SH2.SchDoc	Drawn By: G. De Luca

Comment	Description	Designator	Footprint	LibRef	Quantity
.1uF	Condensatore multistrato 100 Volt	C1, C2, C8, C15, C16	CAP_200	CAP_200	5
100pF	Condensatore multistrato 100 Volt	C3, C17, C19	CAP_200	CAP_200	3
10pF	Condensatore multistrato 100 Volt	C4	CAP_200	CAP_200	1
.001uF	Condensatore multistrato 100 Volt	C5	CAP_200	CAP_200	1
.0047uF	Condensatore multistrato 100 Volt	C6	CAP_200	CAP_200	1
10uF	Polarized Capacitor (Radiale)	C7, C10	CAP_EL_4mm	Cap 1uF	2
1uF	Polarized Capacitor (Radiale)	C12, C13	CAP_EL_4mm	Cap 1uF	2
.002uF	Condensatore multistrato 100 Volt	C14	CAP_200	CAP_200	1
4.7pF	Condensatore multistrato 100 Volt	C18	CAP_200	CAP_200	1
1N4148	High Conductance Fast Diode	D1, D2, D3, D4, D5, D6, D7, D8	DO-35	Diode 1N4148	8
BF247	N-Channel FET	Q1	TO-92D - BF247	BF247	1
10K	Resistenza 1/4W passo 10mm	R1, R12, R13, R17, R25, R32, R35, R40, R42, R4 R71	RES10	RES passo 10	11
10K	Trimmer Multigin VR5	R5, R7	VR5	TRIMMER VR5	2
100K	Resistenza 1/4W passo 10mm	R6, R10, R15, R18, R23, R27, R29, R31, R44, R5 R66, R67	RES10	RES passo 10	12
1M	Resistenza 1/4W passo 10mm	R8, R28, R30, R45, R69	RES10	RES passo 10	5
4.7K	Resistenza 1/4W passo 10mm	R9, R36, R52	RES10	RES passo 10	3
20K	Trimmer Multigin VR5	R11	VR5	TRIMMER VR5	1
20K	Resistenza 1/4W passo 10mm	R14, R21, R48	RES10	RES passo 10	3
100R	Trimmer Multigin VR5	R16	VR5	TRIMMER VR5	1
475R	Resistenza 1/4W passo 10mm	R19	RES10	RES passo 10	1
47K	Resistenza 1/4W passo 10mm	R20, R65	RES10	RES passo 10	2
1K	Resistenza 1/4W passo 10mm	R22, R26, R34, R49, R5	RES10	RES passo 10	5
2K	Resistenza 1/4W passo 10mm	R24	RES20	RES passo 10	1
3K	Resistenza 1/4W passo 10mm	R41	RES10	RES passo 10	1
2K	Resistenza 1/4W passo 10mm	R46	RES10	RES passo 10	1
130K	Resistenza 1/4W passo 10mm	R53	RES10	RES passo 10	1
200K	Resistenza 1/4W passo 10mm	R56, R57	RES10	RES passo 10	2
1M	Trimmer Multigin VR5	R59	VR5	TRIMMER VR5	1
100K	Trimmer Multigin VR5	R60, R64	VR5	TRIMMER VR5	2
470K	Resistenza 1/4W passo 10mm	R61	RES10	RES passo 10	1
10M	Resistenza 1/4W passo 10mm	R68	RES10	RES passo 10	1
18K	Resistenza 1/4W passo 10mm	R70	RES10	RES passo 10	1
R3P2	Test Point 2x2 mm	TP1	Test Point 2	Test Point 2	1
R2P2	Test Point 2x2 mm	TP2	Test Point 2	Test Point 2	1
CV1	Test Point 2x2 mm	TP3	Test Point 2	Test Point 2	1
CV2	Test Point 2x2 mm	TP4	Test Point 2	Test Point 2	1
CV3	Test Point 2x2 mm	TP5	Test Point 2	Test Point 2	1
CV4	Test Point 2x2 mm	TP6	Test Point 2	Test Point 2	1
LIN	Test Point 2x2 mm	TP7	Test Point 2	Test Point 2	1
R3P1	Test Point 2x2 mm	TP8	Test Point 2	Test Point 2	1
R2P1	Test Point 2x2 mm	TP9	Test Point 2	Test Point 2	1
R3P3	Test Point 2x2 mm	TP10	Test Point 2	Test Point 2	1
R2P3	Test Point 2x2 mm	TP11	Test Point 2	Test Point 2	1
SYNC	Test Point 2x2 mm	TP12	Test Point 2	Test Point 2	1
SIN	Test Point 2x2 mm	TP13	Test Point 2	Test Point 2	1
TRI	Test Point 2x2 mm	TP14	Test Point 2	Test Point 2	1
PWM	Test Point 2x2 mm	TP15	Test Point 2	Test Point 2	1
SQR	Test Point 2x2 mm	TP16	Test Point 2	Test Point 2	1
R39P2	Test Point 2x2 mm	TP17	Test Point 2	Test Point 2	1
R39P3	Test Point 2x2 mm	TP18	Test Point 2	Test Point 2	1
R39P1	Test Point 2x2 mm	TP19	Test Point 2	Test Point 2	1
RMP	Test Point 2x2 mm	TP20	Test Point 2	Test Point 2	1
+12V	Test Point 2x2 mm	TP21, TP22	Test Point 2	Test Point 2	2
GND	Test Point 2x2 mm	TP23, TP24	Test Point 2	Test Point 2	2
-12V	Test Point 2x2 mm	TP25, TP26	Test Point 2	Test Point 2	2
OP275	Dual JFET-Input Operational Amplifier	U1	DIP8	OP275	1
TL082	Operational Amplifier	U2	DIP8	TL082	1
CA3146	High Voltage Transistor Array	U3	DIP14	CA3146	1
TL074	Quad JFET-Input Operational Amplifier	U4	14DIP	TL074	1
LM13700	Dual Operational Transconductance	U5	DIP16	LM13700	1
TL072	Dual JFET-Input Operational Amplifier	U6	DIP8	TL082	1
TL071	FET-Input Operational A	U7	DIP8	TL071	1